

Horizontal Cable Systems

DESIGN·RAIL®

1) Check Contents Of Packages: Verify that all parts have arrived and that they match the packing list.

2) Anchor Posts: Position all main *posts* (space *posts* a maximum of 5' or 6' on center - depending on system). The *posts* for the *Threaded Terminal* fittings (with 9/32" holes) and the *posts* for the *Quick-Connect®SS* fittings (with 3/8" holes) should be positioned at opposite ends, and the *intermediate posts* (with 3/16") holes positioned in between. Remember, you must have a minimum of 3" of thread penetration into solid wood for proper attachment; additional wood blocking and/or longer bolts may be required.

- *Surface mounting:* anchor each *post* using provided hardware (see detailed sheet included in your order) with *retaining washers* and *large plastic caps*.
- *Fascia mounting:* anchor each *post* using provided hardware with *retaining washers* and *large plastic caps*. Finish with an *internal post cap* by pre-drilling post & screwing a #8 x 3/4" pan head screw through the side of the post and cap flange to secure cap.

If you are mounting posts using the *stanchion mount* or *fascia bracket mount* methods, please call for additional installation details.

3) Cut & Snap Cap Rails: Cut the *cap rail* to length and then snap it into position on top of the *posts*. Be sure to attach *decorative end plates* (see step #5) to any ends that butt-up against a wall face or that have limited access.

- *Butt splices:* always cut the *cap rail* at 90 degrees and center the joint over a *post*. Use a rectangular splice plate with four #8 x 3/4" pan head screws to secure this joint.
- *Mitered joints with double corner posts:* the *cap rail* will extend past each of the corner *posts* and the actual miter joint will be unsupported. Remember to cut each *cap rail* miter at 1/2 the total corner angle (i.e. if the corner angle is 90 degrees, cut each miter at 45 degrees). Add one *splice plate* to connect and stabilize the miter joint. Insert the plate before setting the two rail sections down of top of the posts; use eight (8) #8 x 3/4" pan head screws to secure the *splice plate* to the rails.
- *Mitered joints with single corner posts:* cut each *cap rail* miter at 1/2 the total corner angle (i.e. if the corner angle is 90 degrees, cut each miter at 45 degrees) Center the joint over the corner *post*. Add one *splice plate* to connect and stabilize the miter joint. Insert the plate before setting the two rail sections down of top of the *post*; use eight (8) #8 x 3/4" pan head screws to secure the *splice plate* to the rails. Also, on each side of the miter cut, screw a #8 x 3/4" pan head screw through the *cap rail* flange and into the *post* face.

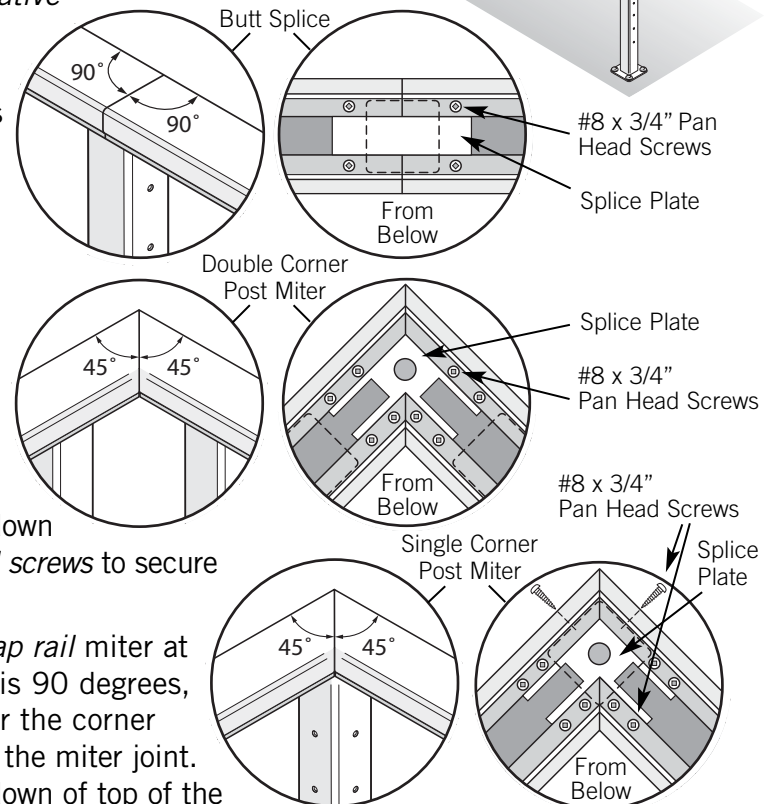
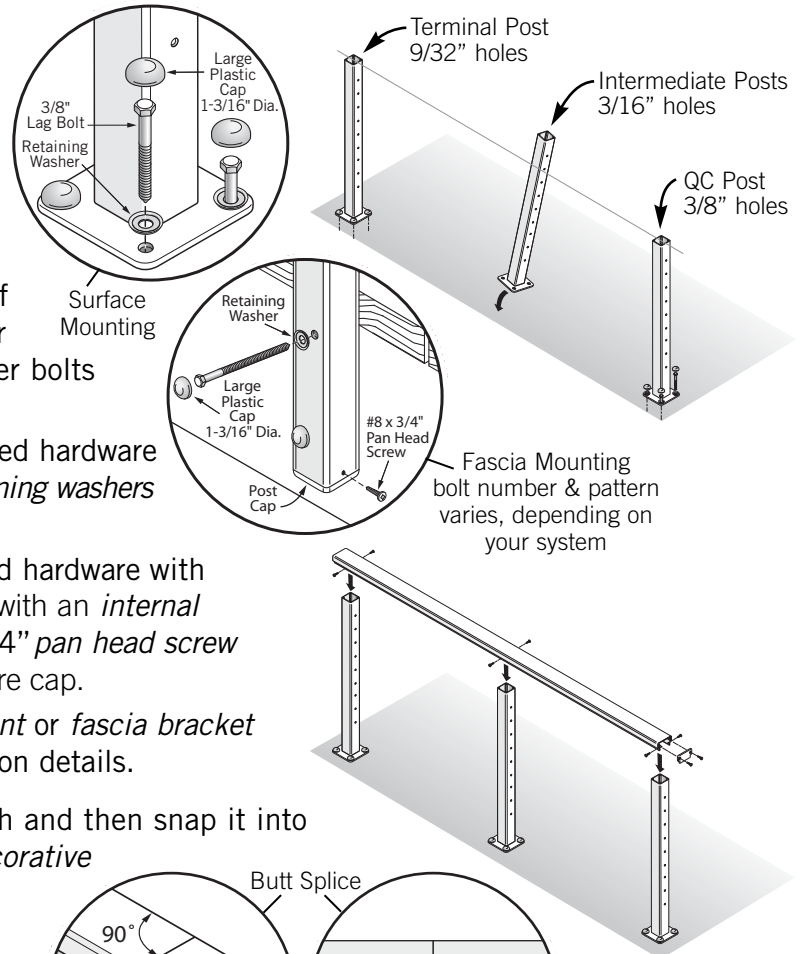

continued on next page

4) Fasten Cap Rails: Secure the *cap rail* to each *post* using two #8 x 3/4" *pan head screws* (four screws for butt splices); screws should run through the *cap rail* flange and into the center of the *post* face. Attach screws to both the front and back of each post.

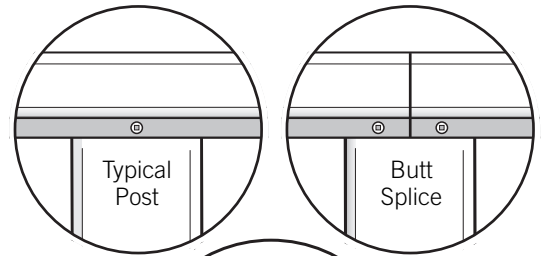

5) Attach Decorative End Caps: Attach the *decorative end caps* to all of the exposed *cap rail* ends using two #8 x 1" *flat head screws*. (If not using a *foot rail* then skip to step #8)

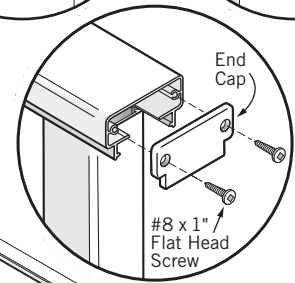

6) Attach RCBs: If using a *foot rail*, locate the *rail connecting block* (RCB) holes on each *post* (these are pre-drilled except on stair rail posts where all the holes must be drilled in the field). Attach the RCBs to the posts using two #10 x 1-3/4" *pan head screws*. The RCBs should be mounted wings down for frames using *cab* systems.

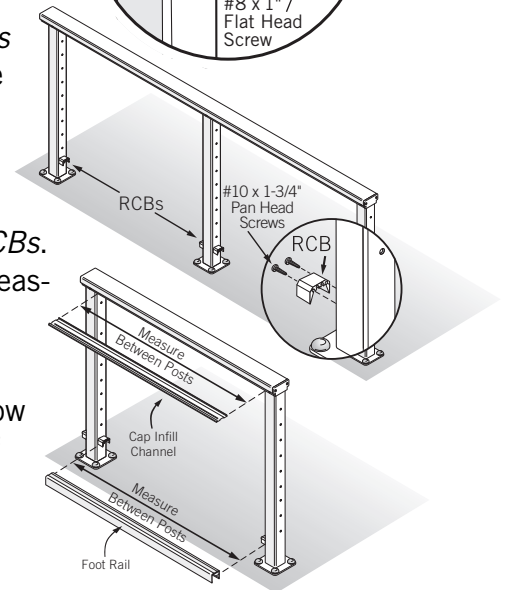

7) Cut Foot Rails: Measure between each set of *posts* just above the RCBs. Cut the *foot rail* for each section to +0/-1/16" of your corresponding measurement. Do not attach the *foot rails* to the frame at this time.

8) Cut Cap Infill Channels: Measure between each set of *posts* just below the *cap rail*. Cut the *cap infill channel* for each section to +0/-1/16" of your corresponding measurement. Do not attach the *cap infill channels* to the *cap rail* at this time.

9) Locate & Drill Picket Attachment Holes: If your *posts* are spaced more than 3 feet apart, you will need at least one mid-span *picket* placed between each set of *posts* (quantity & spacing of mid-span *pickets* will depend on your frame design). Determine the position of the *pickets* to create equally spaced sections between posts. Drill 1/4" diameter holes in the *cap infill channels* and *foot rails* (if applicable) at all picket locations. Please note that each *picket* has a built-in screw chase hole located on the inside edge of the *picket*, **not the center** of the *picket* (see diagram); therefore you'll need to slightly offset the 1/4" holes to line up the screw chase hole.

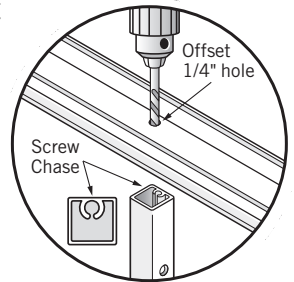

10) Attach Pickets To Cap Infill Channel: Identify which end is the top end of each *picket* by comparing the spacing of the first cable hole in each *picket* to that of the first (top) pre-drilled cable hole on the *posts*. Using the #10 x 3/4" *pan head screws* attach the top end of the *picket(s)* to the *cap infill channel*. (If not using a *foot rails* then skip to step #13).

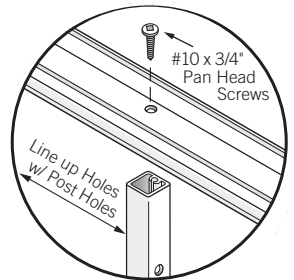

11) Attach Pickets To Foot Rail: Using the #10 x 3/4" *pan head screws* attach the bottom end of the *picket(s)* to the *foot rail*. Assemble all sections using the same procedure.

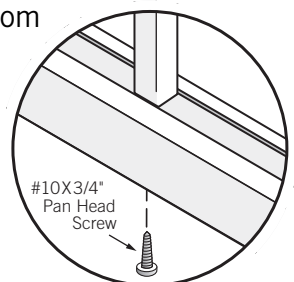

continued on next page

12) Install Assembled Picket Panels: Lift the panels (assembled *cap infill channel, foot rail & picket*) into position on the frame by first setting the *foot rail* on top of the *RCBs* and then tilting the panel vertically into position. The top of the *cap infill channel* should just clear the bottom of the *cap rail*. At this point you should be able to lift the entire section up by the *cap infill channel* and snap it up into place inside the *cap rail*. Use two #8 x 3/4" *pan head screws* to fasten the *foot rail* to each *RCB*. Pre-drill these holes with a 9/64" drill bit before attaching screws, as the wings of the *RCBs* tend to flex when pushed by a *pan head screw*. Also, be sure to slightly offset opposing screw holes so that the screws don't hit one another inside the *RCB*. Complete this for all sections. You are now ready to install the cables. **(Skip to step #14).**

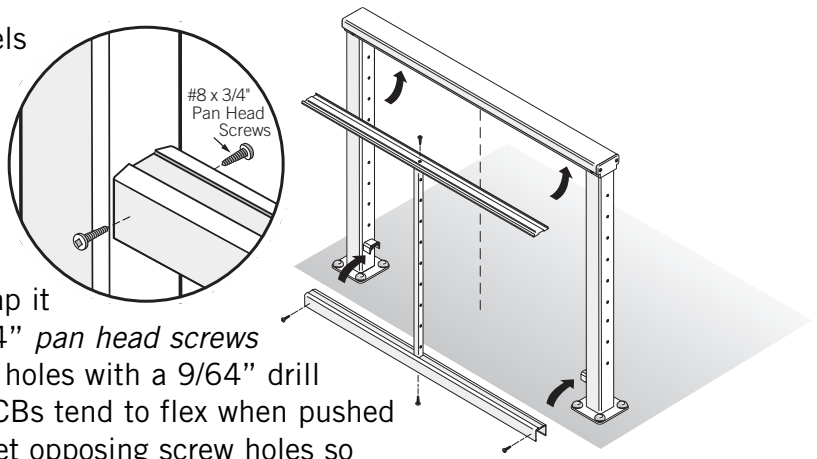

13) Install Assembled Picket Panels Using Picket Base:

Loosely slip a *picket base* onto the bottom of each of the *pickets*. Slide the entire panel (*cap infill channel, picket & picket base*) into position under the *cap rail* then lift and snap the *cap infill channel* into the bottom of the *cap rail*. Line-up and plumb each *picket* and secure the *picket base* to the deck surface using two #12 x 1" *flat head screws*. A #8 x 3/4" *pan head screw* can be used to center and secure the *picket* to the *picket base*. You are now ready to install the cables.

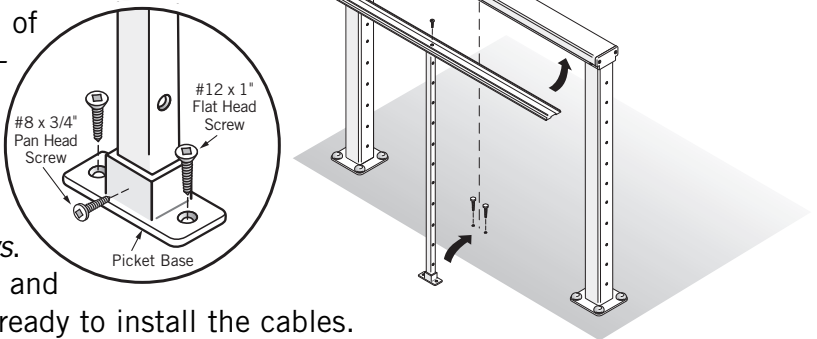

14) Install The CableRail Cables (applies to horizontal cables only—not stairs):

- Identify the proper length cable assemblies for each run of railing.
- To start, pass the *Threaded Terminals* through the *Threaded Terminal end post* (9/32" holes) and attach a *nylon flat washer* and *Snug-Grip® washer nut* onto the end of each *terminal*.
- Spin the *washer-nut* so that approximately 1/4" of the thread is exposed on the end.
- Using a *lacing needle* (optional tool item), lace the free end of the cable through all of the *intermediate posts* and *pickets* and continue through the *Quick-Connect®SS end post* (3/8" holes) at the opposite end.
- Slip a *nylon flat washer* and *Quick-Connect®SS* fitting on to each cable end, and slide them into the *post* until they rest against the *post* face.
- Holding the *Quick-Connect®SS* with one hand, pull the cable tight with the other. The fitting automatically locks when you release the cable.
- Using a 7/16" wrench, tighten the *Snug-Grip® washer nuts* until the cables are taut. Hold the shaft of the *Threaded Terminal* with *Vise-grip®* pliers while tightening.

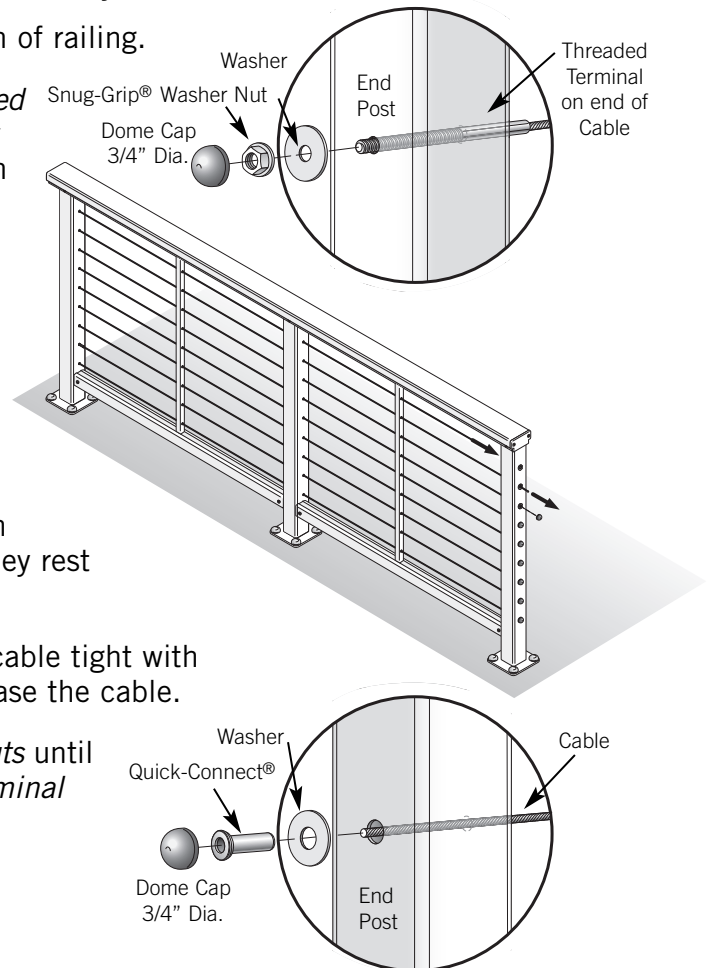

continued on next page

- Saw off the excess threads as close to the *washer-nut* as possible, and touch up cut ends with an electric grinder.
- Using cable cutters or a cut-off disk, trim the excess cable from behind the *Quick-Connect*®SS fitting, and grind flush any exposed ends with an electric grinder.
- Snap-on the *colored vinyl dome caps* (or accessory option *stainless steel end caps*) over the lip of the exposed *Quick-Connect*®SS fittings and *Snug-Grip*® *washer nuts*. You're done.

Maintenance: Any scratches on the railing can be refinished with touch-up paint. Frames and cables can be cleaned with warm soapy water and a sponge or soft cloth.